



FuelMaker

Model FMQ-2/
FMQ-2.5/FMQ-2-36

Vehicle Refueling Appliance



Operating Instructions

**This Equipment Shall Only Be Used By A Properly Trained
Vehicle Owner Or Operator**

*FuelMaker Corporation
70 Worcester Road, Toronto, Ontario, Canada, M9W 5X2
4745 Amelia Earhart Drive, Suite 470, Salt Lake City, Utah, U.S.A. 84116
Technical Support (North America): 1-800-263-8569
Technical Support (International): 001-416-674-3034 (extension 258)
Internet: www.fuelmaker.com*

SAFETY INSTRUCTIONS

PLEASE READ CAREFULLY

1. NO USER-SERVICEABLE COMPONENTS

The FuelMaker FMQ-2/FMQ-2.5/FMQ-2-36 Modules (Control Module, Compression Module, and Electronics Module) must be installed and serviced by personnel specifically trained and authorized by FuelMaker Corporation.

Modules must not be dismantled in the field. To do so will void all warranties and could result in serious injury.

2. READ INSTRUCTIONS CAREFULLY

Please read this manual carefully and those of any other FuelMaker Equipment supplied prior to installation and operation. If you are unsure about any feature or are experiencing any difficulties, please contact FuelMaker's Technical Support Group at:

1-800-263-8569 (North America)
001-416-674-3034 extension 258 (International)

3. LOCATION OF THE FUELMAKER

The VRA is to be installed outdoors in non-hazardous locations as defined by the C22.1 Canadian Electrical Code (Canada), and the NEC National Electrical Code (USA). Do not install the VRA under or near a window or directly under potential gas accumulating overhangs. Leaves, snow and other debris should be kept clear of the air inlet and outlet of the VRA. The VRA and the vehicle cylinders must be located so they are both exposed to the same ambient temperature during refueling.

4. FOR REFUELING NATURAL GAS VEHICLES ONLY

Attempts to use the VRA for any other purpose could result in serious injury or death. Vehicle cylinders must be certified for Natural Gas storage at 3000 psig (207 bar) or higher for the FMQ-2 / FMQ-2.5 and 3600 psig (248 bar) or higher for the FMQ-2-36. The FuelMaker may be used for residential and commercial applications in accordance with the requirements of the authorities having jurisdiction.

5. REFUELING PRECAUTIONS

Do not run vehicle engine while refueling and ensure all ignition sources are OFF (including pilot lights in recreational vehicles). Do not smoke or bring an open flame within 3 metres (10 ft.) of the vehicle being refueled.

6. IF YOU SMELL GAS

Shut off the manually-operated valve in the gas supply to the VRA. If possible, close the manual gas valve in the vehicle. Extinguish any open flames. Contact an authorized service representative.

7. REFUELING HOSE

The fill hose must be protected from physical damage, abrasion or from being driven over. When a sign of wear, deterioration, or other damage is apparent in the hose or hose connector, the hose or hose connector must be inspected or replaced immediately by an authorized service representative.

CAUTION

NEVER USE ACETONE, THINNER, OR OTHER STRONG CHEMICAL AGENTS ON THE PLASTIC HOUSING. TO CLEAN THE OUTER SURFACES USE ONLY MILD SOAPS AND HOUSEHOLD CLEANERS.



TABLE OF CONTENTS

	Page
1 INTRODUCTION	1
2 TECHNICAL SPECIFICATIONS	1
3 OPERATING PARAMETERS	
Delivery-Side Refueling Components	2
Temperature/Pressure Compensation	2
Vent Connection	3
Verification of Proper Installation	3
4 USER PANEL OPERATION	
4.1 User Panel Indications	5
4.2 Abnormal User Panel Indications (Flashing Lights)	6
4.3 Indicator Lights Check	6
4.4 Service Hours	6
5 FAULT DIAGNOSTICS	
5.1 Diagnostics When In "INCORRECT" Mode	7
5.2 Diagnostics When In "CALL FOR SERVICE" Mode	12
 TABLES and FIGURES	
Table 1 Technical Specifications	1
Table 2 Shutdown Pressure vs Ambient Temperature	3
Table 3 Hours Remaining Before Service	7
Table 4 Diagnostics For "INCORRECT" Mode	8
Table 5 Diagnostics For "CALL FOR SERVICE" Mode	12
Table 6 Installation Details	13
Figure 1 VRA Unit	4
Figure 2 User Panel	5

1 INTRODUCTION

Model FMQ-2/FMQ-2.5/FMQ-2-36 VRAs are self-contained, oil-free outdoor appliances used for compressing Natural Gas. The VRA can be used in direct fill applications where one or two hoses are connected to the vehicle to be filled or; remote fill applications where one or more hoses of a remote panel or auxiliary fueling panel are connected to the vehicle or; manifold fill application where the VRAs are hard piped to ground storage. The FMQ-2 will fill a 100 litre (26.4 US gal) gas cylinder to a pressure of 20.7 MPa @ 21°C (3000 psig @ 70°F) within 7.5 hours. The FMQ-2.5 will fill a 100 litre (26.4 US gal) gas cylinder to a pressure of 20.7 MPa @ 21°C (3000 psig @ 70°F) within 6.0 hours. The FMQ-2-36 will fill a 100 litre (26.4 US gal) gas cylinder to a pressure of 24.8 MPa @ 15°C (3600 psig @ 59°F) within 9 hours. The flow rate is roughly the energy equivalent to about 3.7 litres (1 US gal) to 4.4 litres (1.2 US gal) of gasoline per hour, depending on the model and energy content of Natural Gas. The VRA is equipped with automatic temperature compensation and will shut down at a maximum pressure determined by the temperature sensed at the VRA air inlet.

Each appliance is air-cooled and is rated for an operating ambient temperature range of -40°C to +45°C (-40°F to

+113°F). The air is drawn into the VRA through one set of vents in the rear of the housing (See Figure 2) and exhausted through another set of vents in the front of the housing (See Figure 2). The FuelMaker has a hinged lid to allow access to the *User Panel* and vehicle fill hose/refueling nozzle (See Figure 2). Starting, stopping and monitoring of the VRA takes place at the *User Panel*.

Important: FMQ-2 and FMQ-2.5 are CGA and AGA certified for Canada and the United States. FMQ-2-36 is AGA certified only for the United States.

Note: VRAs equipped with *Pressure Start System* are AGA certified for commercial and industrial applications only for the United States of America.

Safety precautions require that the VRA's internal parts be inaccessible to the User and other unauthorized personnel, and accordingly the Service Cover is sealed by authorized service personnel before they leave the site. **Only authorized service representatives may service the VRA at the User's premises.**

2 TECHNICAL SPECIFICATIONS

GAS	FMQ-2	FMQ-2.5	FMQ-2-36
Maximum Discharge Pressure:	20.7 MPa (3000 psig) @ 21° C (70° F)	20.7 MPa (3000 psig) @ 21° C (70° F)	24.8 MPa (3600 psig) @ 15° C (59° F)
Minimum Inlet Pressure:	1.7 kPa (7" w.c.)	1.7 kPa (7" w.c.)	1.7 kPa (7" w.c.)
Maximum Inlet Pressure:	14 kPa (2 psig)	3.5 kPa (14" w.c.)	3.5 kPa (14" w.c.)
Nominal Flow Rate (60Hz)	3.4 m ³ /hr @ 21°C and 1.7 kPa inlet (2.0 scfm @ 70°F and 7" w.c. inlet)	4.25 m ³ /hr @ 21°C and 1.7 kPa inlet (2.5 scfm @ 70°F and 7" w.c. inlet)	3.1 m ³ /hr @ 15°C and 1.7 kPa inlet (1.8 SCFM @ 59°F and 7" w.c. inlet)
ELECTRICAL			
Electrical Supply:	208*/240 Volt AC, Single Phase, 60 Hz 220 Volt AC, Single Phase, 50 Hz	240 Volt AC, Single Phase, 60 Hz 220 Volt AC, Single Phase, 50 Hz	240 Volt AC, Single Phase, 60 Hz 220 Volt AC, Single Phase, 50 Hz
Circuit Ampacity:	15 Amps	15 Amps	15 Amps
Full Load Amperage (60/50 Hz):	7.0 / 6.5 Amps	8.0 / 7.25 Amps	7.0 / 6.5 Amps
Average Power Consumption :	0.9 to 1.2 kWh * Subject to FuelMaker evaluation and approval	1.1 to 1.5 kWh	0.9 to 1.2 kWh
MECHANICAL			
Dimensions (L x W x H):	540 x 500 x 990 mm (21" x 20" x 39")	540 x 500 x 990 mm (21" x 20" x 39")	540 x 500 x 990 mm (21" x 20" x 39")
Unit Weight:	66 kg (145 lbs)	66 kg (145 lbs)	66 kg (145 lbs)
Sound Level:	49 dBA @ 5 m (16.5 ft.), hemispherical field	49 dBA @ 5 m (16.5 ft.), hemispherical field	49 dBA @ 5 m (16.5 ft.), hemispherical field
With noise reduction package:	45 dBA @ 5 m (16.5 ft.), hemispherical field	45 dBA @ 5 m (16.5 ft.), hemispherical field	45 dBA @ 5 m (16.5 ft.), hemispherical field
Ambient Temperature Rating:	-40° C to +45° C (-40° F to +113° F)	-40° C to +45° C (-40° F to +113° F)	-40° C to +45° C (-40° F to +113° F)

3 OPERATING PARAMETERS

Delivery-Side Refueling Components

The VRA is supplied with a fibre-reinforced coiled high pressure hose to deliver fuel to the vehicle. Optional hose lengths of up to 8 m (26 ft) are available by special order. The hose is connected to the VRA via a break-away fitting which allows the hose to be pulled free from the VRA without damage should the User drive the vehicle away without disconnecting. The break-away force is approximately 150 N (34 lbs.) and is independent of the pressure contained in the fill hose. The VRA will shut down immediately after a break-away occurs. The fill hose can be easily re-connected by pushing the hose tip into the Breakaway Guide (Figure 1) until it snaps positively into position.

The VRA must be used with a refueling nozzle that is approved for Natural Gas “Slow-Fill” applications. The nozzle must seal reliably throughout the temperature range and conditions anticipated for the location. An integral normally-closed poppet valve in the nozzle is absolutely essential as it must maintain a positive pressure in the VRA’s Blow-down System at all times; air must not migrate up the fill hose and into the Blow-down Vessel during standby. The use of the Canadian Gas Association (CGA) Certification Seal is contingent upon the use of a refueling nozzle that has been either application-approved for use with the VRA, or CGA certified as a natural gas vehicle fueling connection device.

Application-approved nozzles include:

SHEREX Model CC-260 and CC270

Source: Sherex Industries Ltd., Burlington, Ontario, Canada

FuelMaker Corporation has done, and continues to perform, extensive testing on fueling nozzles. Please contact FuelMaker for recommendations

At the completion of each refueling cycle the high pressure gas contained downstream of the compressor is returned to a Blow-down Vessel thus reducing the pressure in the fill hose to approximately 2 bar (29 psig). “Blow-down” allows the nozzle to be disconnected from the vehicle. The VRA Blow-down System has been designed to accommodate the volume of gas contained by the fill hose, refueling nozzle, and the space between the vehicle receptacle and check valve only. Therefore, the allowable maximum length of fill hose has been limited to a combined length of 9 m (29 ft.) on model FMQ-2 & FMQ-2.5 VRAs and 6 m (20 ft.) on model FMQ-2-36 VRAs, which accounts for the fact that two fill hoses may be used on one VRA. Single hose lengths of 2 m (7 ft.) to 7.5 m (25 ft.) are available. The length of a single fill hose is limited by code, to 7.5 m (25 ft.) maximum.

Do not connect additional devices or hose lengths to the delivery side of the VRA. To do so will over-pressurize the Blow-down System and cause the pressure relief valve to vent Natural Gas to the atmosphere. Do not connect any hose or device which has not been approved as part of the Vehicle Refueling Appliance package. Contact the local authority having jurisdiction for requirements pertaining to manifolding VRAs or connecting VRAs to ground storage.

Temperature/Pressure Compensation

The VRA contains a temperature sensor in the inlet air stream which determines the allowable fill pressure for a particular ambient temperature. Once a cylinder has been refueled, any increase in ambient temperature will cause the pressure to rise in the cylinder. The temperature/pressure compensation feature fills the cylinders with a constant mass of gas, regardless of the ambient temperature. Therefore, in very cold temperatures the fill pressure will be quite low, but the same mass of gas that constitutes a full cylinder is present. This feature prevents the vehicle cylinders from being over-pressurized if the ambient temperature rises (e.g. as the day warms). In order for the temperature/pressure compensation system to function properly, the vehicle to be refueled must be parked in a location where the gas cylinders in the vehicle will be exposed to the same ambient temperature as the temperature sensor located in the air stream of the VRA.

If, after refueling, the maximum filling pressure falls outside the allowable range as indicated in Table 2, “Shutdown Pressure vs Ambient Temperature”, contact an authorized service representative to have the VRA serviced.

Model FMQ-2 & FMQ-2.5

207 ± 7.0 bar @ 21°C and above	3000 ± 100 psig @ 70°F and above
183 ± 7.5 bar @ 10°C	2660 ± 110 psig @ 50°F
166 ± 8.0 bar @ 0°C	2410 ± 115 psig @ 32°F
150 ± 8.5 bar @ -10°C	2180 ± 120 psig @ 14°F
133 ± 9.0 bar @ -20°C	1930 ± 130 psig @ -4°F
116 ± 9.5 bar @ -30°C	1690 ± 135 psig @ -22°F
100 ± 10 bar @ -40°C	1450 ± 145 psig @ -40°F

At temperatures below -45°C (-49°F) and +55°C (131°F) the micro-processor will not allow the VRA to start, and indicate an "Incorrect" condition at the user panel.

Model FMQ-2-36

248 ± 7.0 bar @ 15°C and above	3600 ± 100 psig @ 59°F and above
232 ± 7.5 bar @ 10°C	3370 ± 110 psig @ 50°F
210 ± 8.0 bar @ 0°C	3050 ± 115 psig @ 32°F
188 ± 8.5 bar @ -10°C	2730 ± 120 psig @ 14°F
165 ± 9.0 bar @ -20°C	2390 ± 130 psig @ -4°F
143 ± 9.5 bar @ -30°C	2073 ± 135 psig @ -22°F
121 ± 10 bar @ -40°C	1754 ± 145 psig @ -40°F

At temperatures below -45°C (-49°F) and +55°C (131°F) the micro-processor will not allow the VRA to start, and indicate an "Incorrect" condition at the user panel.

Table 2 Shutdown Pressure vs Ambient Temperature

Vent Connection

A 3/8" NPT vent port is located as shown in Figure 1 and is protected from blockage by ice or insects by a screen fitting. The vent port discharges any gas released by the pressure relief valve in order to protect the *blow-down system* from over-pressurization.

Do not allow ice to build up at the open vent connection; it must remain clear if it is to be able to vent gas and protect the *blow-down system* from over-pressurization.

Verification of Proper Installation

The VRA should be installed outdoors only and be mounted on a firm, level, non-combustible base such as a poured or precast concrete slab placed on a suitably prepared base (e.g. crushed stone, 150 mm (6") deep). Areas should be avoided where damage from excessive ice build-up may occur such as building overhangs or where vegetation, snow or debris may clog the cooling air inlet/outlet. The VRA should not be situated where the vehicle refueling hose must cross a walkway or access route to reach the vehicle.

If the VRA is installed near building openings, a 10 mm (3/8") minimum inside diameter steel vent line should be connected to the vent port and routed to a safe place of discharge as required by local codes. The maximum allowable vent line length is limited to 5 m (16.5 ft.) to protect the low-pressure switch from over-pressurization. The screen fitting should (if applicable) be transferred to the end of a remote vent line to protect it from blockage. **It is extremely important to have the remote vent line terminated in such a way that water cannot enter the vent line and freeze.**

The VRA should only be installed in distribution areas of relatively dry gas, typically containing not more than 110 mg/m³ (7 lbs per million cubic feet) of water vapour. It is recommended that units not be located where direct or reflected noise is aimed at neighbouring windows or other building openings. The VRA should be positioned in a location where it will not become damaged from possible vehicle impact. If the VRA is located close to a driveway, provision should be made to protect the unit from damage. It is very important to bolt the VRA to the base as the unit must resist the break-away force applied to it in the event of a break-away (e.g. vehicle driving away with the *fill hose* still attached).

Verification of Proper Installation (cont'd)

The VRA can be programmed by the Installer, to change the following parameters in the field:

- recognition of remote panel connected.
- maximum tank volume, 140 or 280 litres (37 or 74 US gal.)
- recognition of remote shutdown device (eg. Natural Gas Detector) connected.
- pressure rise monitoring ON/OFF

Upon receipt of a new VRA, the parameters have been factory-set to: remote panel not connected, 280 litres, shutdown device not connected, and pressure rise monitoring ON. The VRA monitors the pressure rise at the fill hose during refueling in order to check for possible leaks. A leak is presumed if the pressure does not rise at a sufficient rate.

Since the rate of pressure rise depends on the volume of the vehicle tanks, some adjustment must be made to accommodate the slower pressure rise associated with the larger tanks; the Installer can program such an adjustment. For the greatest leak detection sensitivity, the lowest tank setting (140 litres) should be used, unless the tank volume exceeds 140 litres. In the rare case where the tank volume is in excess of 280 litres, the pressure rise monitoring system will have to be programmed to shut off; this setting should not be used unless absolutely necessary and the User should be aware that hose leakage will not be monitored in this case. If an interlocking (remote shutdown) device such as a timer or Natural Gas detector has been connected to the VRA, the Installer must program the VRA to acknowledge the presence of the device.

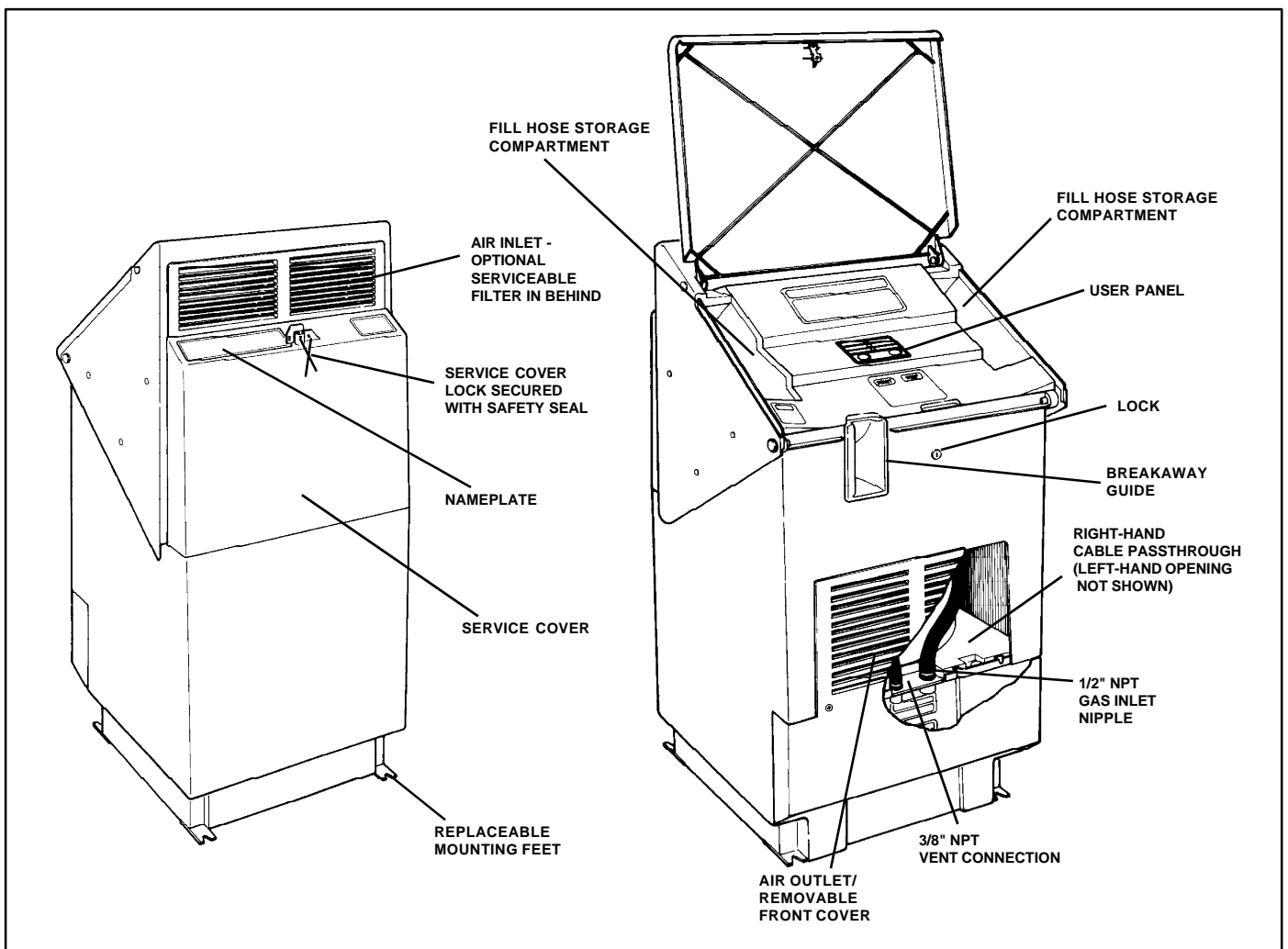

Figure 1 VRA Unit

4 USER PANEL OPERATION

Starting, stopping and monitoring of the VRA takes place at the *user panel*. The *user panel* has separate "START" and "STOP" buttons and three indicator lights, as shown in Figure 2.

After shut-down the pressure in the refueling hose will be automatically reduced to about .20 MPa (29 psig) making it possible to disconnect the refueling nozzle from the vehicle.

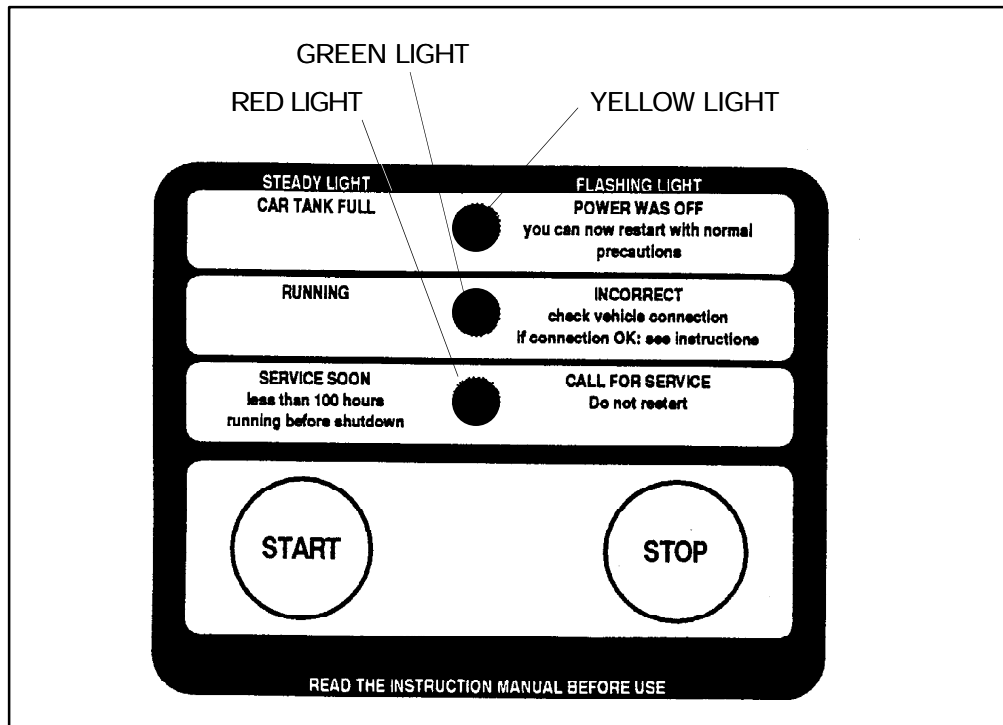

Figure 2 - User Panel

The lights on the *user panel* indicate the following conditions:

4.1 USER PANEL INDICATIONS

INDICATION	DESCRIPTION
No Light Illuminated	READY to start, or electrical power is disconnected, or fuses require replacement. Note: If a power failure lasts less than 15 seconds, the VRA will start automatically 15 seconds after the return of power (provided it was running before the power failure).
Yellow Light Steady	VEHICLE CYLINDER(S) FULL The vehicle is full or the maximum pressure has been reached in a disconnected fill hose. The VRA can be restarted by pressing the START button.
Green Light Steady	RUNNING The VRA is running.
Red Light Steady	SERVICE SOON The VRA will run for another 100 hours after which it will shut down if not serviced. Note: During the last 100 hours of operation, both the green light and red light will illuminate steadily while the VRA is in operation.

4.2 ABNORMAL USER PANEL INDICATIONS (FLASHING LIGHTS)

INDICATION	DESCRIPTION
Yellow Light Flashing	<p>POWER WAS OFF for more than 15 seconds. Press START to operate the VRA. Note: If the power failure lasts for less than 15 seconds, the VRA will start automatically 15 seconds after the return of power (provided it was running before the power failure).</p>
Green Light Flashing	<p>INCORRECT - The VRA is shut down in an INCORRECT state but may be restarted by the User if the fault is corrected. The most common causes of an "INCORRECT" indication will be:</p> <ul style="list-style-type: none"> - incorrect or damaged connection to the vehicle. - gas supply shut-off valve closed. - blockage of VRA air vents. - faulty filling hose e.g. leak or excessive filling time (25 hours continuous running). <p>Note: Vehicles with total tank capacities in excess of 140 litres (37 US gal) may take longer than 25 hours to fill from empty under certain conditions (e.g. high ambient temperature, <i>compression module</i> approaching service interval, etc.) In this case, a thorough check for gas leakage shall be conducted. The VRA may be simply restarted after a positive check that there is no other cause of the "INCORRECT" indication. If the User is routinely filling vehicles with a cylinder capacity greater than 140 litres, the maximum tank volume can be set using a programming device.</p> <p>Details on the above faults are given in the "FAULT DIAGNOSTICS" tables. When the above have been checked and any obvious faults corrected, the unit may be restarted after first pressing the "STOP" button.</p>
Red Light Flashing	<p>CALL FOR SERVICE - The VRA is shut down and a CALL FOR SERVICE is necessary. The automatic safety system will prevent a restart unless the fault is corrected by authorized personnel.</p>
Yellow, Green and Red lights flashing (simultaneously)	<p>HOUR-METER MISSING - The VRA is shut down and the automatic safety system will prevent a restart. IMPORTANT: Before plugging the <i>hour-meter</i> into the <i>electronics module</i> circuit board, the main electrical power must be disconnected. Hour-meter data will be destroyed if power is not disconnected and the VRA will not re-start unless the <i>compression module</i> is changed.</p>
Yellow, Green and Red lights flashing (sequentially)	<p>SYSTEM LOCKOUT FOR APPROXIMATELY 15 SECONDS - The VRA automatic safety system will prevent immediate restart due to internal requirements.</p>

**4.3 INDICATOR LIGHTS CHECK:
(VRA NOT RUNNING)**

To check that the indicator lights are working correctly, press and hold the **STOP** button. All three indicator lights should light briefly, for about one second, and then go out; if none light, there is probably no power to the *electronics module* or the fuses require replacement. (If one or more indicator lights fail to illuminate there is probably an error in the *user panel*).

4.4 SERVICE HOURS:

Table 3 displays the operating hours until the VRA requires service (or hours since service up to the first 50 hours). To obtain the indications, the following button(s) have to be pressed:

When the VRA is **"RUNNING"**:
Press and hold the **"START"** button.

When the VRA is not running:
First press and hold the **"STOP"** button, then press the **"START"** button.

After the code is displayed, release the **"START"** button first, followed by the **"STOP"** button (the VRA will not start if this sequence is not followed)

At first, all lights are illuminated briefly as a light check. The light check is followed by the operating hours check.

(1 = steady light; 0 = off)								
Yellow	0	0	0	0	1	1	1	1
Green	0	0	1	1	0	0	1	1
Red	0	1	0	1	0	1	0	1
	Hours since service		Hours remaining until service					
Hours	fault or no power	0 - 49	650- max	350- 649	250- 349	150- 249	50- 149	0 - 49

Table 3 - Hours remaining before service

5 FAULT DIAGNOSTICS (Software Version 64):

The VRA has diagnostic capabilities both in the "INCORRECT" (green light flashing) and the "CALL FOR SERVICE" (red light flashing) mode. To display the cause of an "INCORRECT" or a "CALL FOR SERVICE" mode, press and hold the "STOP" button. Tables 4 and 5 show the fault diagnostics and corrective actions.

The digits 0, 1 and 2 in Tables 4 and 5 correspond to the following light status.

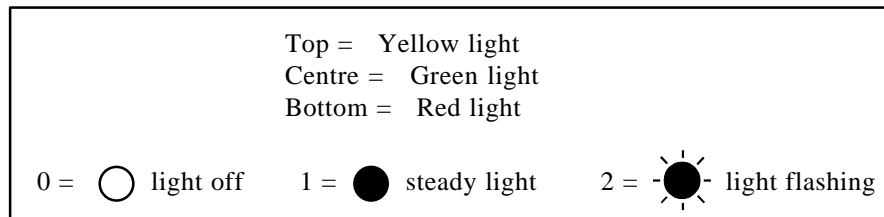

5.1 DIAGNOSTICS WHEN IN "INCORRECT" MODE (GREEN LIGHT FLASHING) :

Pressing and holding the "STOP" button first acts as a light check by illuminating all 3 lights briefly. After this brief delay, error codes are displayed:

ERROR CODE	DESCRIPTION	CORRECTIVE ACTION
0 YEL off 0 GRN off 0 RED off	Error indication lost or error in display, <i>electronics module</i> , or in connecting cables.	Check power and lights by pressing and holding "STOP" button. All lights should illuminate briefly. If OK: try normal filling procedure. If fault persists, contact authorized service representative.
0 YEL off 0 GRN off 1 RED steady	Excessive motor temperature	Check if cooling air path is clear. If OK: try normal filling procedure. If fault persists, contact authorized service representative.
0 YEL off 1 GRN steady 0 RED off	Insufficient rise of filling pressure at beginning of fill cycle and below 20 bar g, during first 5 minutes. [7 minutes for 280 litre (74 US gal.) setting].	Check that refueling nozzle is properly connected to vehicle. If OK: check that total vehicle cylinder volume does not exceed the maximum volume of 140 litres (37 US gal) [may be reset to 280 litres (74 US gal.) by authorized service representative]. If OK: check high-pressure system for leaks. If leaks are found, contact authorized service representative. If no leaks are found, restart the VRA. If fault persists, contact authorized service representative.

Table 4 - Diagnostics for "INCORRECT" Mode.

ERROR CODE		DESCRIPTION	CORRECTIVE ACTION
0	○ YEL off	Sudden pressure drop in high pressure system to below 20 bar g (290 psig).	<p>Check high pressure system for leaks.</p> <p>If OK:start VRA with refueling nozzle disconnected from vehicle (approved refueling nozzles will seal when disconnected from vehicle). Allow VRA to run until FULL is indicated.</p> <p>If the VRA continues to run for longer than 1 minute with disconnected refueling nozzle, contact authorized service representative</p>
1	● GRN steady		
1	● RED steady		
<p>Note: This indication can also result from:</p> <p>a) simultaneously filling two vehicles if either of the vehicle check valves stick, or if a second vehicle is connected while the VRA is running. To start filling procedure, always connect the refueling nozzle to the vehicle receptacle first, open the nozzle shut-off valve if provided, and subsequently start the VRA.</p> <p>b) hydrate blockages (snow-like) within the fill hose fittings that are suddenly blown clear. Low temperatures and wet gas contribute to hydrate formation.</p>			
0	○ YEL off	External interlock (remote shut down).	<p>Check condition which caused interlock (if an external interlock has been installed). Restart the unit, if safe to do so.</p>
2	☼ GRN flashing		
1	● RED steady		
1	● YEL steady	Temperature too low or failure of temperature sensor.	<p>Restart unit if cause was temperature below -45°C (-49°F). Otherwise, contact authorized service representative.</p>
0	○ GRN off		
0	○ RED off		
1	● YEL steady	Insufficient inlet pressure.	<p>Check that the main Natural Gas supply valve is open.</p> <p>If OK:restart the unit.</p> <p>If fault persists, contact authorized service representative.</p>
0	○ GRN off		
1	● RED steady		
1	● YEL steady	Excessive surface temperature or failure of temperature sensor while the VRA is running.	<p>Check if cooling air path is clear.</p> <p>If OK:restart the VRA.</p> <p>If fault persists, contact an authorized service representative.</p>
0	○ GRN off		
2	☼ RED flashing		

Table 4 - Diagnostics for "INCORRECT" Mode.

ERROR CODE		DESCRIPTION	CORRECTIVE ACTION
1	● YEL steady	Stop button sequencing error.	Press " STOP " button then " START " button to restart the unit. If fault persists , contact authorized service representative.
1	● GRN steady		
0	○ RED off		
1	● YEL steady	Electronics error.	Press " STOP " button then " START " button to restart the unit. If fault persists , contact authorized service representative.
1	● GRN steady		
1	● RED steady		
1	● YEL off	No storage of operating hours during last power failure.	Restart the unit.
1	● GRN steady		
2	⦿ RED flashing		
1	● YEL steady	Failure of Motor Controls.	Restart the unit. If fault persists , contact authorized service representative.
2	⦿ GRN flashing		
0	○ RED off		
1	● YEL steady	Fast Pressure Rise.	Ensure that the refueling hose is properly connected to the vehicle or test kit. IF OK: Check for refueling hose blockage. IF OK: Restart the unit.
2	⦿ GRN flashing		
1	● RED steady		
1	● YEL steady	Maximum running time exceeded (more than 25 hours).	Check that the maximum cylinder volume does not exceed the maximum volume of 140 litres (37 US gal.) [may be reset to 280 litres (74 US gal.)by authorized service representative]. If cylinder volume correct , check for leaks (smell). If leaks detected , contact authorized service representative. If no leaks detected , restart the unit and complete the fill. If fault persists , contact authorized service representative.
2	⦿ GRN flashing		
2	⦿ RED flashing		

Table 4 - Diagnostics for "INCORRECT" Mode (continued)

























ERROR CODE		DESCRIPTION	CORRECTIVE ACTION
2	 YEL flashing	Power was off.	Restart the unit.
0	 GRN off		
0	 RED off		
2	 YEL flashing	Failure of Blow-down system.	<p>If refueling nozzle is difficult to disconnect, reduce pressure in the hose by closing the fuel supply valve between the vehicle cylinder(s) and engine, then start and run the engine until it quits. Open the fuel supply valve and restart the unit.</p> <p>If fault persists, contact authorized service representative.</p>
0	 GRN off		
1	 RED steady		
2	 YEL off	Insufficient pressure rise [with tank pressure exceeding 2 bar g (290 psig) or beyond 6 minutes after start up]	<p>Check high pressure system for leaks.</p> <p>If OK: turn off gas supply and restart the VRA. It should shut down within 1 minute indicating "INCORRECT" 101.</p> <p>If fault persists, contact an authorized service representative.</p>
1	 GRN steady		
0	 RED off		
2	 YEL steady	Faulty Hour-meter	<p>Restart the unit.</p> <p>If fault persists, contact authorized service representative.</p>
2	 GRN flashing		
0	 RED off		

Table 4 - Diagnostics for "INCORRECT" Mode (continued)

5.2 DIAGNOSTICS WHEN IN "CALL FOR SERVICE" MODE (RED LIGHT FLASHING):

Pressing and holding the "STOP" button first acts as a light check by illuminating all three lights briefly. After this brief delay, the error codes described in Table 5 are displayed by pressing and holding the "STOP" button.

Up to five error codes are stored and retrieved by repetitively pressing the "START" button, **while the "STOP" button remains pressed continuously**, until the 222 code (end of stored messages) is given. Corrective action may only be performed by authorized service personnel.

ERROR CODE		DESCRIPTION
0	 YEL off	Service Overdue
0	 GRN off	
2	 RED steady	
0	 YEL off	Excessive blow-down pressure or vehicle check valve stuck.
1	 GRN steady	
2	 RED flashing	
0	 YEL off	Failure of high pressure transducer.
2	 GRN flashing	
0	 RED off	
1	 YEL steady	Stop button sequencing error.
0	 GRN off	
1	 RED steady	









ERROR CODE		DESCRIPTION
1	 YEL flashing	Failure of motor controls.
2	 GRN off	
0	 RED off	
2	 YEL flashing	Faulty hour-meter.
2	 GRN off	
0	 RED steady	
2	 YEL off	End of stored messages.
2	 GRN steady	
2	 RED off	

Table 5 - Diagnostics for "CALL FOR SERVICE" Mode

